

MATERIAL MUST BE ACCORD WITH RoHS STANDARD

版本 REV.	变更内容 DESCRIPTION	变更号 ECN No.	日期 DATE
1.0	ISSUE	REL	2020-04-14

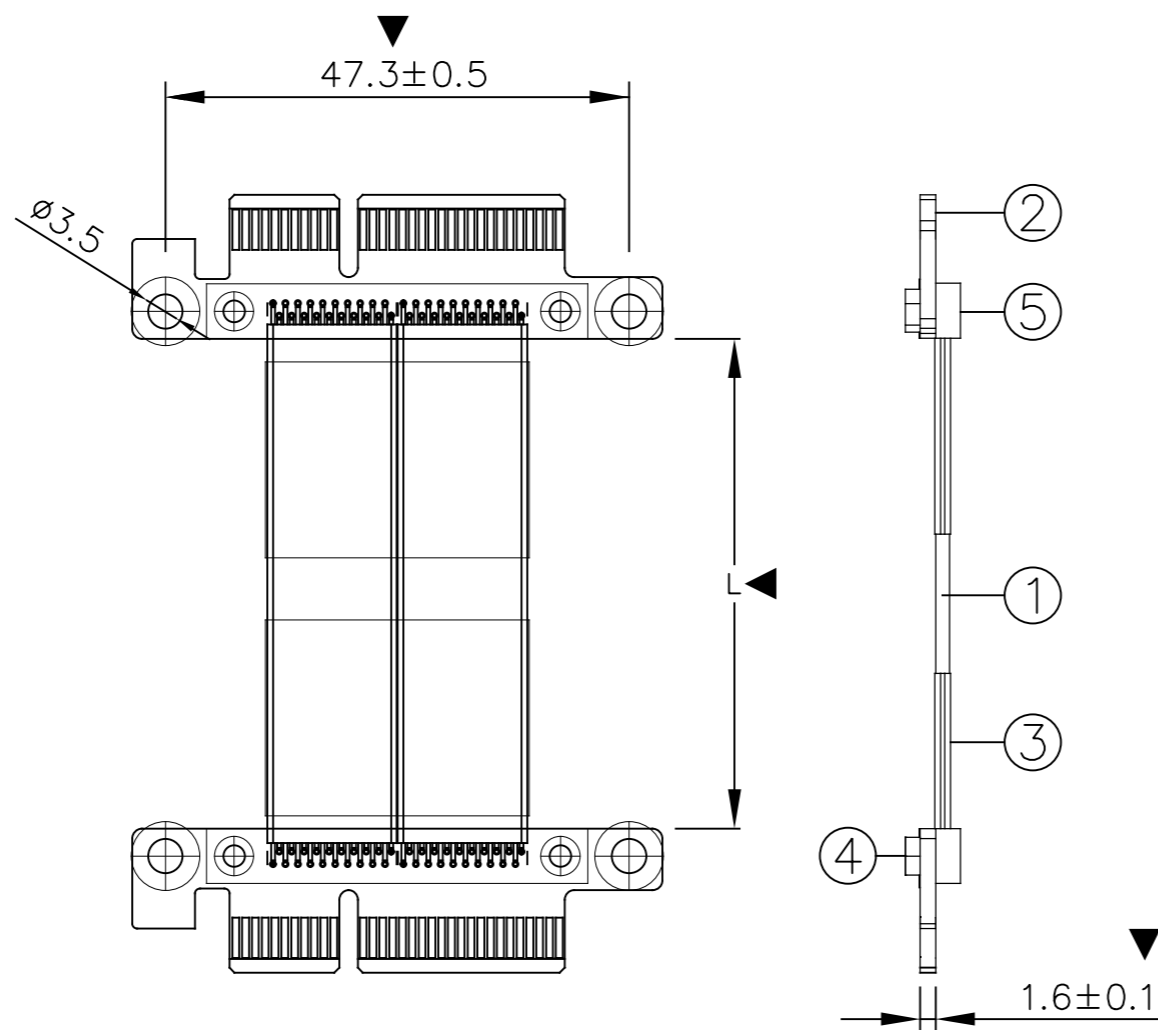

NOTE
 1.100% PCIe 3.0 8Gb/s x4 TEST.
 2.DIMSION MARK "▼" BY QC CHECK.



R22NS-5cm	50±5
R22NS-10cm	100±5
R22NS-15cm	150±5
R22NS-20cm	200±10
R22NS-25cm	250±10
R22NS-30cm	300±20
R22NS-40cm	400±20
R22NS-50cm	500±20
R22NS-80cm	800±30
Part-Number	Length (mm)

ADT-LINK

TITLE: PCI-E x4 Extension CABLE L=5~80cm	DWG NO.: ADT-R2N-R2S-001
	CUSTOMER NO.: ADT
	CUSTOMER P/N: R22NS-xxxcm

	SCALE	UNIT	CUS REV.	HY REV.	DATE	SHEET
	NONE	mm	1.0	1.0	2020-04-14	1/1

DRAWING/制图 CHECKED/审核 APPROVED/核准

No.	PART NO.	DESCRIPTION	Q'TY
5	PAD	3mm thickness FR4 PCB PAD	2Pcs
4	Screw	M2 screw & hex nut	4Pcs
3	Tape	Acetate cloth tape	2Pcs
2	PCB	PCI-E x4 64P edge	2Pcs
1	CABLE	HIGH SPEED FLAT CABLE,(WIRE20P=30AWG×12P,28AWG×8P),PE JACKET: BLACK,OD=1.4×13.2mm (95±15Ω),TPE	2Pcs